

MANUFACTURERS
"AFC" LOGO
.025 MAX
RAISED OR INDENTED

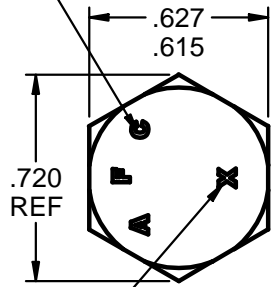

"X" ALLOY STEEL
GRADE MARK

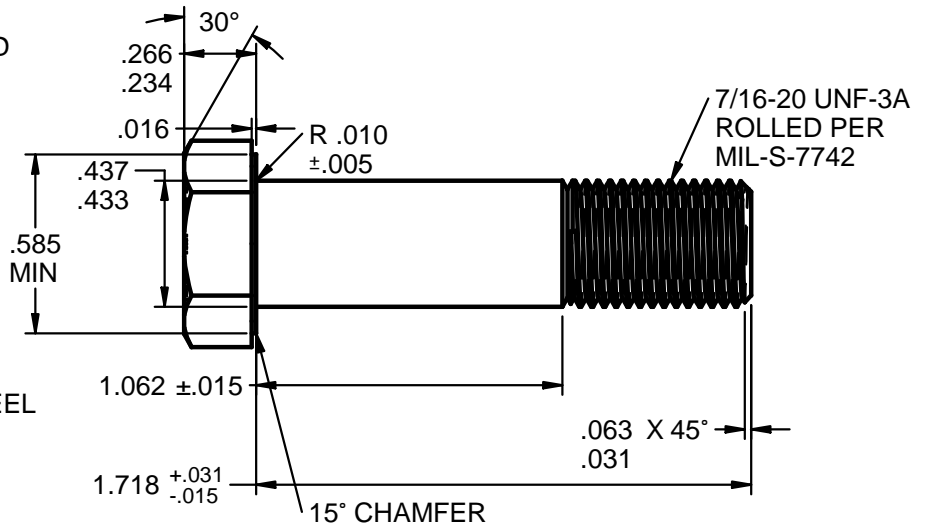

SCALE: 1.5X

DESIGN NOTES: AN7-15A AIRFRAME BOLT

1. LENGTH 1-23/32" (1.718"), GRIP 1-1/16" (1.062"), THREAD 7/16-20 UNF-3A.
2. PROCUREMENT SPECIFICATION NASM6812.
3. MATERIAL ALLOY STEEL PER PROCUREMENT SPECIFICATION.
UNS G40370 AMS6300 DFAR EXEMPT
UNS G87400 AMS6322 DFAR APPLIES
UNS G41400 AMS6382 DFAR APPLIES
UNS G41300 AMS-S-6758 DFAR APPLIES
4. HEAT TREAT AMS-2759 HRC 26-32.
5. FINISH CADMIUM PLATED PER AMS-QQ-P-416, TYPE 2 (YELLOW), CLASS 2.
6. THREADS 7/16-20 UNF-3A ROLLED PROCESS PER MIL-S-7742.
7. TENSILE 13,600 LBS. [60,495 N] MIN.
8. YIELD 10,430 LBS. [46,394 N] MIN.
9. SINGLE SHEAR 11,250 LBS. [50,042 N] MIN. SHORT LENGTH N/A.

EXAMPLE PART NUMBER

AFC 7-15 C2 - CADMIUM TYPE 2 YELLOW PLATING
AFC 7-15 C1 - CADMIUM TYPE 1 PLAIN WHITE PLATING
AFC 7-15 TDC - THERMAL DIFFUSION COATED ASTM A1059

↑ FINISH
 ↑ LENGTH 1.718"
 ↑ BODY SIZE & THREAD .437-20 UNF-3A
 ↑ MANUFACTURER AIRFASCO



ACTUAL SIZE

UNCONTROLLED

CONFORMS TO: NASM3 THRU NASM20
PART NUMBER: AN7-15A

DIMENSIONS ARE IN INCHES AND TOLERANCES ARE AS SHOWN BELOW. DIMENSIONAL TOLERANCES AND SYMBOLS PER ANSI Y14.5M-1982	PROPRIETARY PARTS SHOWN IN THIS DRAWING ARE THE SUBJECT OF ISSUED UNITED STATES AND FOREIGN PATENTS AND PATENTS PENDING. UNAUTHORIZED REPRODUCTION AND/OR DISTRIBUTION OF THIS DRAWING IS STRICTLY PROHIBITED.		AIRFASCO.com	
	2655 HARRISON AVE SW, CANTON, OHIO 44706 USA			
	APPROVALS	DATE	PART NUMBER: AN7-15A_AFC7-15C2	REV
ANGLES ±5°	DRAWN M.B.	4/11/14	SIZE A	MATERIAL: 4037 / 8740 OR AS NOTED
.XX ±.03"	CHECKED T.W.	4/11/14	EST. WEIGHT: .090 / EACH LBS. [41.0 g]	
.XXX ±.010"	ENG APPR B.E.	4/11/14	SCALE: 1.5X	DRAWING NUMBER: AN7-15A_AFC7-15C2
.XXXX ±.001"	MGR APPR D.D.	4/11/14	SHEET 1 OF 1	