

MANUFACTURERS
"AFC" LOGO
.025 MAX
RAISED OR INDENTED

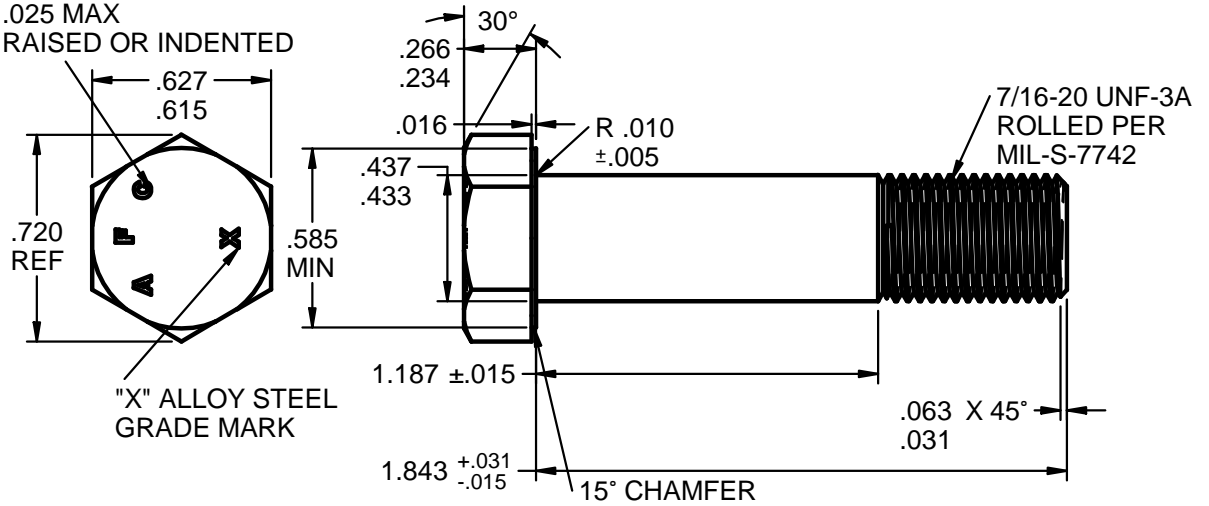

SCALE: 1.5X

DESIGN NOTES: AN7-16A AIRFRAME BOLT

1. LENGTH 1-27/32" (1.843"), GRIP 1-3/16" (1.187"), THREAD 7/16-20 UNF-3A.
2. PROCUREMENT SPECIFICATION NASM6812.
3. MATERIAL ALLOY STEEL PER PROCUREMENT SPECIFICATION.
UNS G40370 AMS6300 DFAR EXEMPT
UNS G87400 AMS6322 DFAR APPLIES
UNS G41400 AMS6382 DFAR APPLIES
UNS G41300 AMS-S-6758 DFAR APPLIES
4. HEAT TREAT AMS-2759 HRC 26-32.
5. FINISH CADMIUM PLATED PER AMS-QQ-P-416, TYPE 2 (YELLOW), CLASS 2.
6. THREADS 7/16-20 UNF-3A ROLLED PROCESS PER MIL-S-7742.
7. TENSILE 13,600 LBS. [60,495 N] MIN.
8. YIELD 10,430 LBS. [46,394 N] MIN.
9. SINGLE SHEAR 11,250 LBS. [50,042 N] MIN. SHORT LENGTH N/A.

EXAMPLE PART NUMBER

AFC 7-16 C2- CADMIUM TYPE 2 YELLOW PLATING
 AFC 7-16 C1- CADMIUM TYPE 1 PLAIN WHITE PLATING
 AFC 7-16 TDC- THERMAL DIFFUSION COATED ASTM A1059

↑ FINISH
 ↑ LENGTH 1.843"
 ↑ BODY SIZE & THREAD .437-20 UNF-3A
 ↑ MANUFACTURER AIRFASCO



ACTUAL SIZE

UNCONTROLLED

CONFORMS TO: NASM3 THRU NASM20
PART NUMBER: AN7-16A

DIMENSIONS ARE IN INCHES AND TOLERANCES ARE AS SHOWN BELOW. DIMENSIONAL TOLERANCES AND SYMBOLS PER ANSI Y14.5M-1982	PROPRIETARY PARTS SHOWN IN THIS DRAWING ARE THE SUBJECT OF ISSUED UNITED STATES AND FOREIGN PATENTS AND PATENTS PENDING. UNAUTHORIZED REPRODUCTION AND/OR DISTRIBUTION OF THIS DRAWING IS STRICTLY PROHIBITED.		AIRFASCO.com	
	2655 HARRISON AVE SW, CANTON, OHIO 44706 USA			
	APPROVALS	DATE	PART NUMBER: AN7-16A_AFC7-16C2	REV
ANGLES	±5°	DRAWN M.B.	4/11/14	
.XX	±.03"	CHECKED T.W.	4/11/14	
.XXX	±.010"	ENG APPR B.E.	4/11/14	
.XXXX	±.001"	MGR APPR D.D.	4/11/14	
		SIZE A	MATERIAL: 4037 / 8740 OR AS NOTED	EST. WEIGHT: .096 / EACH LBS. [43.6 g]
		SCALE: 1.5X	DRAWING NUMBER: AN7-16A_AFC7-16C2	SHEET 1 OF 1